

*Issued on behalf of the UK CAA by the BMAA, UK CAA organisation approval ref. DAI/8909/84*

TYPE: **JA-600 Skyleader 600**

- (1) MANUFACTURER: Air Operation Technologies A.S., Hruskove Dvory 139, 58601  
Jihlava, Czech Republic.  
Approval Ref: DAI/9987/24
- (2) UK IMPORTER: Inditu Air Services Ltd. trading as Skyleader UK
- (3) CERTIFICATION: UL 2 – Part I, 2019 edition and BCAR Section S Issue 8
- (4) DEFINITION OF BASIC STANDARD: AOT09-2025-JA6.PE Definition basic standard of the JA-600 Skyleader 600 for UK market.  
Drawing Number: 600 800 - Main Drawing ZM-2023-001 dated 09/01/2023
- (5) COMPLIANCE WITH THE MICROLIGHT DEFINITION
- |  |  |
|--|--|
| (a) MTOW   | 600 kg   |
| (b) No. Seats  | 2  |
| (c) Maximum Wing Loading                                   | 50.63 kg/m <sup>2</sup>                                  |
| (d) V <sub>so</sub>  | 37 knots <b>CAS</b>                                      |
| (e) Permitted range of pilot weights                       | 0-120 kg (each)<br>(min cockpit load 55kg <sup>1</sup> ) |
| (f) Typical Empty Weight (ZFW)                             | 373 kg   |
| (g) ZFW + 200 kg crew + 1 hr fuel                          | 591 kg   |
| (h) ZFW + 100 kg pilot + full fuel<br>(120 litres / 84 kg) | 557 kg   |
| (i) Max ZFW at initial permit issue                        | 382 kg   |

<sup>1</sup> Pilots below 60kg must apply ballast to baggage area

Issued on behalf of the UK CAA by the BMAA, UK CAA organisation approval ref. DAI/8909/84

## (6) POWER PLANTS

Designation	JA-600 Skyleader 600	JA-600 Skyleader 600
Engine Type	Rotax 912 ULS	Rotax 912 ULS
Reduction Gear	2.43:1	2.43:1
Exhaust System	Air Operation Technologies	Air Operation Technologies
Intake System	Airbox air intake	Airbox air intake
Propeller Type	E-Props DUR-3-170-C4-T 3 blade	E-Props GLORIEUSE 3-175-C8-T 3 blade, (CS) variable pitch
Propeller Dia x Pitch	1700mm x 27° Using E-props pitch tool	1750mm Pitch Range 16° Constant speed controller
Maximum static rpm	5500 rpm	5750 rpm
Noise Type Cert No.	N/A	N/A
AAN approving configuration	AAN BMAA-1152	AAN BMAA-1152

## (7) MANDATORY LIMITATIONS:

- |     |                              |   |
|-----|------------------------------|---|
| (a) | Max Take-Off Weight          | 600 kg  |
| (b) | CG Limits                    | Aft limit 521 mm aft of datum (35% MAC)<br>Fwd Limit 387 mm aft of datum (24.5% MAC)                          |
| (c) | CG datum                     | Wing Leading Edge   |
| (d) | Cockpit Loadings             | Total<br>Min (occupant only) 55 kg <sup>2</sup><br>Max (occupants only) 120 kg Each<br>Max Cockpit Load 240kg |
| (e) | Never Exceed Speed, $V_{NE}$ | 147 knots IAS   |
| (f) | Manoeuvring Speed, $V_A$     | 91 knots IAS  |
| (g) | Flap Limiting Speed $V_{FE}$ | 75 knots IAS Stage 1<br>69 knots IAS Stage 2  |
| (g) | Permitted Manoeuvres         | Maximum bank angle 60°<br>Non Aerobatic<br>Normal acceleration limits, +4g / -2g                              |

<sup>2</sup> Pilots below 60kg must apply ballast to baggage area

Issued on behalf of the UK CAA by the BMAA, UK CAA organisation approval ref. DAI/8909/84

(h) Fuel Contents (Max Usable) 120 litres 117 litres (Max Usable)

(i) Power Plant See Table

Engine	Rotax 912 ULS
Max RPM	5800 (5 min)
Max Continuous RPM	5500 (continuous)
MAX Coolant	120°C
MAX EGT	880°C
Fuel Spec	95 RON minimum unleaded to EN 228 Normal, Super or Super Plus, AVGAS 100LL, UL91. (Super Unleaded preferred – see engine manual)
Engine Oil Spec	RON 424, SAE 10 W-40 (See engine manual)
Oil Pressure	Normal 2-5 bar above 3500rpm Min 0.8 bar below 3500rpm Max 7 bar
Oil Temperature	50°C -130°C
Fuel Pressure	0.15 - 0.5bar with fuel pump S/N 11.0036 or later

(8) INSTRUMENTS REQUIRED:

ASI	Altimeter	RPM	Coolant Temp	Oil temp	Oil Pressure	Slip Ball	Audible Stall Warner	Fuel Gauge
0 to 155 knots (min)	Required	0-6000 rpm min	Required	Required	Required	Required	Required	1 per tank

BPRS, Angle of Attack indicator/Stall Warner x2 and a cockpit Electronic CO detector are Mandatory.  
A Manifold Pressure gauge is required if a variable pitch propeller is fitted.  
A voltmeter and compass are recommended.  
If a LiFePO4 battery is fitted, a voltmeter must be fitted or displayed on EFIS.

Issued on behalf of the UK CAA by the BMAA, UK CAA organisation approval ref. DAI/8909/84

(9) CONTROL DEFLECTIONS

Ailerons UP	24° ± 1°	Rudder Left	28° ± 2°
Ailerons Down	16° ± 1°	Rudder Right	28° ± 2°
Fowler Flap Take-Off	10° ± 2°	Trim Up	48mm ± 1
Fowler Flap Landing	35° ± 2°	Trim Down	48mm ± 1
Elevator Up	33° ± 2°		
Elevator Down	28° ± 2°		

(10) PILOT'S NOTES, MAINTENANCE MANUALS REFERENCES:

10.1 Manuals approved for use with this aircraft.

- |     |                             |  |
|-----|-----------------------------|--|
| (a) | Pilot's Operating Handbook: | JA-600 Skyleader 600 Pilot Operating Handbook<br>03/2026 or later issues.  |
| (b) | Maintenance Manual          | JA-600 Skyleader 600 Maintenance Manual<br>04/2024 or later issues.  |
| (c) | GLORIEUSE Propeller         | JA-600 Skyleader 600 Pilot Operating Handbook<br>03/2026 or later issues.<br>EP-IMM-glorieuse-ID1891 Rev. 00 (propeller),<br>EP-IMM-glorieuse-ID1893 Rev. 00 (governor),<br>EP-IMM-glorieuse-ID1895 Rev. 00 (control unit),<br>or later approved issues. |

Engine, propeller, parachute system (if fitted) and other fitted equipment manufacturer's Operating and Maintenance Manuals as appropriate to fitted powerplant and equipment, at their current issues.

10.2 The following placards are to be fitted:

- Flight Limitations Placard (to be visible to pilot)  
Contains airspeed, manoeuvring and loading limitations. See Operator's Manual.
- Engine Limitations Placard (to be located near to engine instruments)  
A placard showing the limitations for all indicated engine parameters is to be mounted close to the engine instruments. Also, main limitations are to be shown as coloured markers (red for danger, amber for caution) on the instrument displays. See Operator's Manual.
- Occupant Warning Placard (to be visible to both occupants)  
See Operator's Manual.
- Fuel Filler Placard (to be located adjacent to the fuel filler cap)  
A placard is to be fitted showing fuel capacity and fuel types. See Operator's Manual.

*Issued on behalf of the UK CAA by the BMAA, UK CAA organisation approval ref. DAI/8909/84*

- (e) Fuel Load Vs Cockpit Load (to be visible to both occupants)  
If MTOW can be exceeded with full fuel and 200kg cockpit weight, the fuel loads at MTOW for cockpit weights of 200kg, 190kg, 180kg etc. at 10kg intervals down to the maximum fuel load. See Operator's Manual.
- (f) Parachute Warning Placards (to be located on the exterior of the aircraft)  
Parachute Warning Placards (to be located on the exterior of the aircraft) Placards complying with BCAR Section S Issue 7 (or later) must be fitted. See Pilot Operators Handbook.
- (g) Secondary Control Markings  
Choke, cabin heat, trim, flaps, fuel shut-off: see Operator's Manual. Other secondary controls are to be placarded as per the associated Operator's Manual or normal aviation practice (if not detailed in associated Operator's Manual).
- (h) ASI Markings  
See Operator's Manual.
- (i) Switches  
All switches are to be marked with function and sense (up=on, down=off).
- (j) Fuses and Circuit Breakers  
All fuses and circuit breakers are to be marked with function and rating.
- (k) Fireproof Metal Plate  
Showing the aircraft nationality and registration marks (e.g. G-ABCD) to be mounted in a prominent position on the engine side firewall.
- (l) Lithium Battery Charge Warning  
Lithium battery charging warning adjacent to battery.

(11) MANDATORY MODIFICATIONS / SERVICE BULLETINS / AIRWORTHINESS DIRECTIVES ETC:

See Annex A for required modifications.

(12) MINIMUM PERFORMANCE AT MAX TAKE-OFF WEIGHT

Rate of Climb: 765 fpm at 60 knots **IAS**. Rotax 912 ULS

Rate of Climb: 850 fpm at 60 knots **IAS**. Rotax 912 ULS, Glorieuse propeller

Stall or Minimum Flying Speed: 35 knots **IAS** at MTOW / idle / full flap.

Issued on behalf of the UK CAA by the BMAA, UK CAA organisation approval ref. DAI/8909/84

Issue History

<u>Issue</u>	<u>Date</u>	<u>Reason and Signatory</u>
1	13th April 2026	Initial issue. Approved for issue by R Mott BMAA CTO.

Issued on behalf of the UK CAA by the BMAA, UK CAA organisation approval ref. DAI/8909/84

Illustration of Aircraft - 3 View

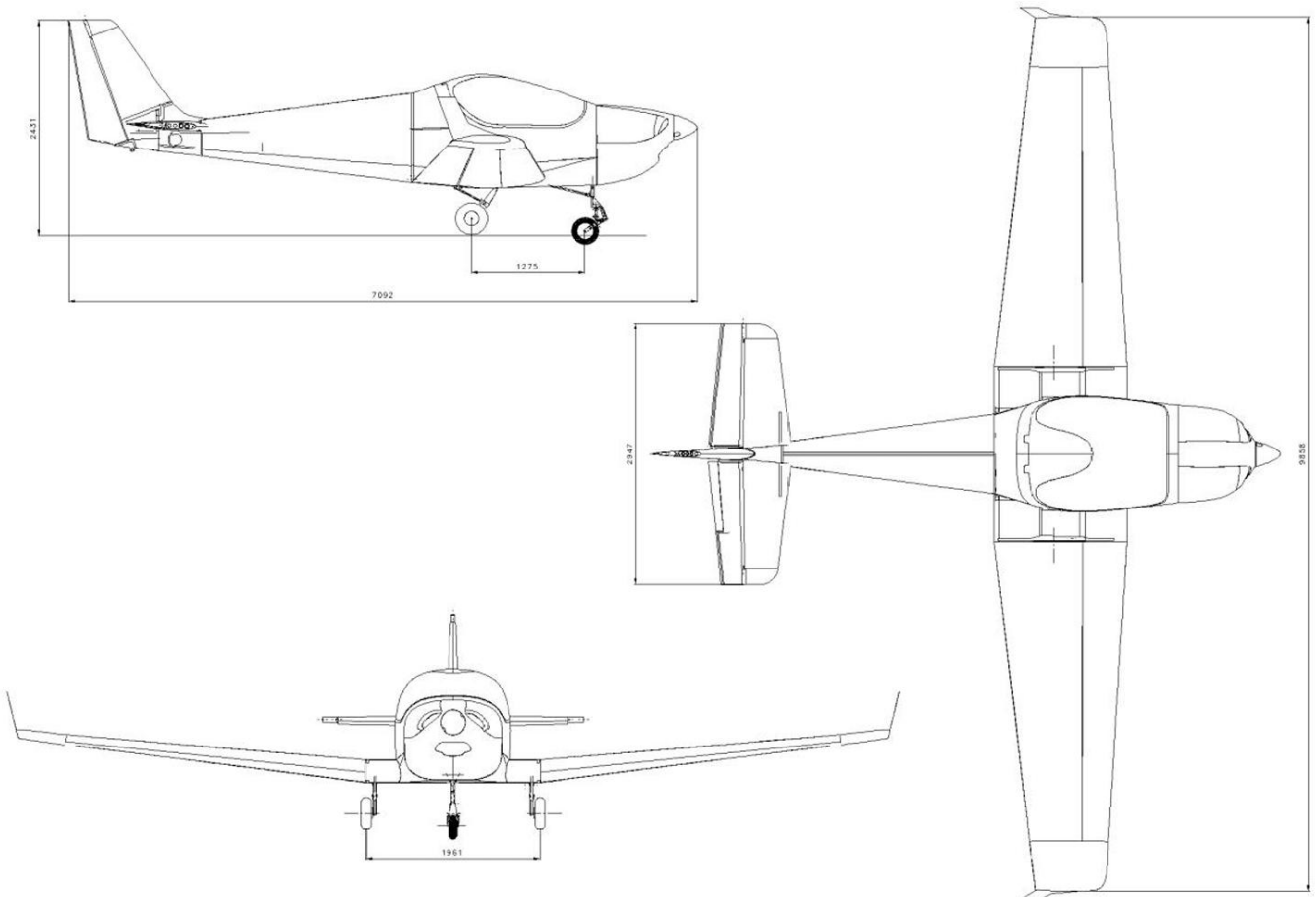

*Issued on behalf of the UK CAA by the BMAA, UK CAA organisation approval ref. DAI/8909/84*

Illustration of Aircraft – Photograph



BRITISH MICROLIGHT AIRCRAFT ASSOCIATION (BMAA)

MICROLIGHT TYPE APPROVAL DATA SHEET (TADS)

NO: BM-108 ISSUE: 1



*Issued on behalf of the UK CAA by the BMAA, UK CAA organisation approval ref. DAI/8909/84*

ANNEX A – MANDATORY MODIFICATIONS/SERVICE BULLETINS/AIRWORTHINESS DIRECTIVES ETC.

**Mandatory Options**

Galaxy GRS 6/600 SD BPRS.

Wing stall strips (one each inboard L/E).

Leading-edge vortex generators ahead of ailerons.

Stall Warner Dynon AOA Pitot, uAvionix AV-20S AOA, AOT Vane AOA or equivalent (any two required)

**For Latest Bulletins**

<https://www.skyleader.cz/zakaznicky-servis?lang=en>

Issued on behalf of the UK CAA by the BMAA, UK CAA organisation approval ref. DAI/8909/84

### ANNEX B - APPROVED OPTIONAL MODIFICATIONS

The installation of all optional modifications is to be inspected by an inspector from an Organisation approved by the CAA for the purpose and an entry made in the appropriate logbook(s). Note that other approved modifications may exist which are not listed here.

Modification No.      Description:

1	E-Props GLORIEUSE 3-175-C8-T CS/VP Propeller
2	Garmin autopilot
3	Dynon autopilot
4	Kanardia autopilot
5	Leather seats
6	Flarm Collision Avoidance System
7	Cabin heater, electronic CO monitor required
8	Dynon Skyview 10"
9	Garmin GDU 450 10" G3X
10	Kanardia HORIS & DIGI (EMS)
11	Analogue Instrument Fit
12	Panel Mount Transceiver (CAA/EASA Approved Types)
13	Panel Mount Transponder (CAA/EASA Approved Types)
14	Panel mount for iPad or similar
15	Carburettor heat
16	Both wing landing light

*Issued on behalf of the UK CAA by the BMAA, UK CAA organisation approval ref. DAI/8909/84*

ANNEX C - WEIGHING INFORMATION

- |                           |  |
|---------------------------|--|
| 1. CG Datum:              | Wing Leading Edge at centre section.                         |
| 2. Weighing attitude:     | Underside of canopy frame at centre section rivet line level |
| 3. Main wheel moment arm: | 760 mm aft from datum, typical*                              |
| 4. Nose wheel moment arm: | -496 mm fwd from datum, typical*                             |
| 5. Fuel moment arm:       | 330 mm aft of datum  |
| 6. Crew moment arm:       | 450 mm - 650 mm aft of datum                                 |
| 7. Baggage moment arm     | 1150 mm aft of datum   |
| 8. Crew weights:          | Minimum 55 kg / maximum 120 kg per seat                      |
| 9. Max baggage weight:    | 30 kg  |
| 10. Aft CG Limit:         | 521 mm aft of datum (35% MAC)                                |
| 11. Fwd CG Limit:         | 387 mm aft of datum (24.5% MAC)                              |

\*See factory measurement for actual aircraft figure when new.

ANNEX D – POINTS FOR SPECIAL ATTENTION

**Tyre Pressures**

Main wheels 2.5 bar (36psi)

Front wheel 2.5 bar (36psi)

**Baggage Allowance**

30 kg evenly spaced (*“spaced for optimum A/C balance”*) and well secured. Always use a safety net.