

MICROLIGHT AIRWORTHINESS APPROVAL NOTE

MAAN NO: 2329

ISSUE 1

DATE: 7 MARCH 2011

TITLE: Microlight Airworthiness Approval Note 2329: Shadow Tailplane Spar and Bush Wear

APPLICABILITY: All BMAA-administered Shadow variants

STAGE: AUTHORISATION

1. INTRODUCTION

The Shadow is a type-approved microlight aeroplane whose variants are described in Microlight TADS BM6, BM19, BM40, BM41 and BM55. The BMAA is responsible for continued airworthiness.

This MAAN authorises the issue of a Service Bulletin in response to in-service experience of this type. The Service Bulletin relates to inspection of the tubular spars of the horizontal tail plane where they mount into the rear of the fuselage tube. The bulletin is appended to this MAAN.

2. BASIS FOR APPROVAL

The basis for authorisation of this Service Bulletin is BCAR Section S Issue 5. Paragraphs affected are S421, S423, S427 and S609.

3. DESCRIPTION

The tubular spars of the horizontal tail plane are located into holes in the rear of the fuselage tube. The spars are supported by thick-walled bushes riveted to the fuselage tube so that the spars do not contact the thin wall of the fuselage tube directly. Nonetheless the spar tubes and the bushes can become worn, and once started, wear is accelerated by the increased clearance. The spar tubes can also then make contact with the fuselage tube.

If left unchecked this wear will significantly weaken the horizontal tail plane spars leading to catastrophic in-flight structural failure of the horizontal tail plane.

BMAA Service Bulletin 2329, appended to this MAAN, introduces an ongoing inspection schedule for all Shadow variants.

4. TECHNICAL INVESTIGATION

The wear proceeds slowly enough so that it should be discovered by the owner during routine inspection, or failing that by a BMAA Inspector at the annual inspection, before it becomes significant. However some examples have developed alarmingly before being discovered. This Service Bulletin is intended to highlight this problem to owners and BMAA Inspectors.

The tail plane spars are sleeved where they pass through the fuselage tube. The port rear spar sleeve has been determined to be the critical case. Wear in excess of 0.73mm has been calculated to be critical from a bending strength perspective. The Service Bulletin limits acceptable wear to 0.6mm at the four wear points.

The inspection can be performed by normal (owner) de-rigging of the tail plane.

5. FLIGHT TESTING

No flight-testing is required.

6. MANUALS, PLACARDS AND INFORMATION

A copy of this Service Bulletin must be retained with the Aircraft Manual.

The pre-flight and 50 hour/annual inspection schedules must be amended to include the inspections specified by the Service Bulletin.

7. NOISE CERTIFICATION

Not affected.

8. RADIO

Any radio installation is not affected.

9. INSPECTION

To the Service Bulletin appended to this MAAN. Also to TADS BM6, BM19, BM40, BM41 or BM55 as appropriate in its latest issue.

10. WEIGHT AND BALANCE

Not affected.

11. SIGNIFICANT FEATURES AND LIMITATIONS

See section 3. All limitations remain unchanged.

12. CERTIFICATION

I authorise issue of BMAA Service Bulletin 2329 Issue 1, as appended to this MAAN.

Prepared by:

Authorised by:

B J Syson
Chief Technical Officer
British Microlight Aircraft Association

B J Syson
Chief Technical Officer
British Microlight Aircraft Association

Initial Distribution.

MAAN (including SB):

CAA Light Aircraft Certification Section (Gatwick)
CAA Applications and Approvals Section (Gatwick)
MAAN File 2329
Shadow post approval file
LAA Engineering

Service Bulletin:

All BMAA-administered Shadow registered owners



BRITISH MICROLIGHT AIRCRAFT ASSOCIATION SERVICE BULLETIN

Reference: BMAA Service Bulletin 2329 Issue 1
Title: Horizontal tail plane spar wear
Applicability: All BMAA-administered Shadows
Author: B J Syson, Chief Technical Officer, BMAA
Effective date: 21 March 2011
Classification: Essential

1. Introduction

The tubular spars of the horizontal tail plane are located into holes in the rear of the fuselage tube. The spars are supported by thick-walled bushes riveted to the fuselage tube so that the spars do not contact the thin wall of the fuselage tube directly. Nonetheless the spar tubes and the bushes can become worn, and once started, wear is accelerated by the increased clearance. The spar tubes can then also make contact with the fuselage tube.

If left unchecked this wear will significantly weaken the horizontal tail plane spars leading to catastrophic in-flight structural failure of the horizontal tail plane.

Parts T119 and T120 are affected – see Figure 1. An example of extreme, and totally unacceptable, wear is shown in Figure 2. Two distinct wear patterns may be seen, caused by contact with the bushes and with the fuselage tube.

2. Aircraft Affected by this Service Bulletin

All Shadow variants in the BMAA fleet: series B/BD, C/CD and D/DD.

3. Implementation of this Service Bulletin

The owner may carry out this Service Bulletin. The tail plane must be de-rigged/rigged in accordance with the aircraft manual.

As part of the *pre-flight* inspection the tail plane spars, where they pass through the bushes in the rear of the fuselage tube, must be inspected for wear. Look for excessive movement of the spars in the bushes (by trying to move each tail plane up and down relative to the fuselage tube). Also look for black wear residue (aluminium oxide) around the bushes. If in doubt de-rig the horizontal tail plane to inspect directly (as described below).

Within **10 flight hours or 3 months** of the effective date (whichever is sooner), and then at least every **50 flight hours or annually** (whichever is sooner), the horizontal tail plane must be de-rigged to inspect the tail plane spars directly. Measure the wear on the spar sleeves; this is best performed using a steel rule laid edgewise along the spar (to provide a straight edge parallel to the undamaged surface) and then the depth measured using a vernier caliper's depth probe. Note: it is the wear below the surface that should be measured, not the reduction in diameter.

Wear of the spars in excess of 0.6mm (0.024") is totally unacceptable from a strength perspective. However wear less than this may also be unacceptable if (possibly combined with wear of the locating bushes) it results in significant 'slop'.

If significant wear is discovered during a pre-flight inspection, record in the airframe logbook. Always record the 50 hour/annual inspection, and any findings, in the airframe logbook. Quote BMAA Service Bulletin 2329.

Any repairs must be made in full accordance with BMAA procedures – contact the BMAA Technical Office.

A copy of this Service Bulletin must be retained with the Aircraft Manual. The pre-flight and 50 hour/annual inspection schedules must be amended to include the inspections specified by the Service Bulletin.

PTO

4. Contact Details

BMAA
Bullring
Deddington
BANBURY
OX15 0TT

01869 336 006
cto@bmaa.org

5. Figures

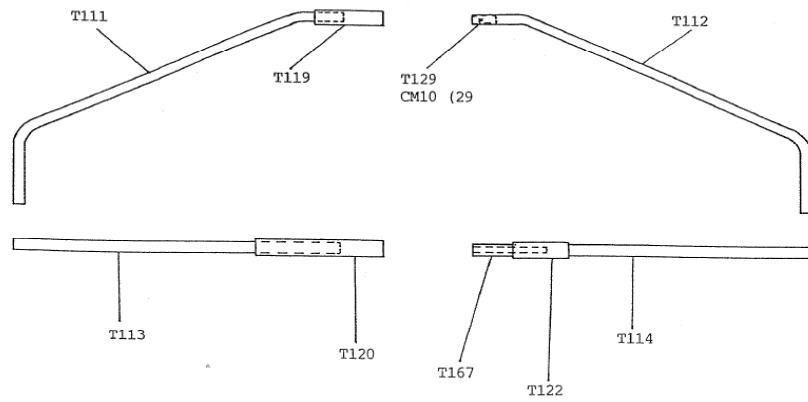

Figure 1: Shadow horizontal tail plane structure

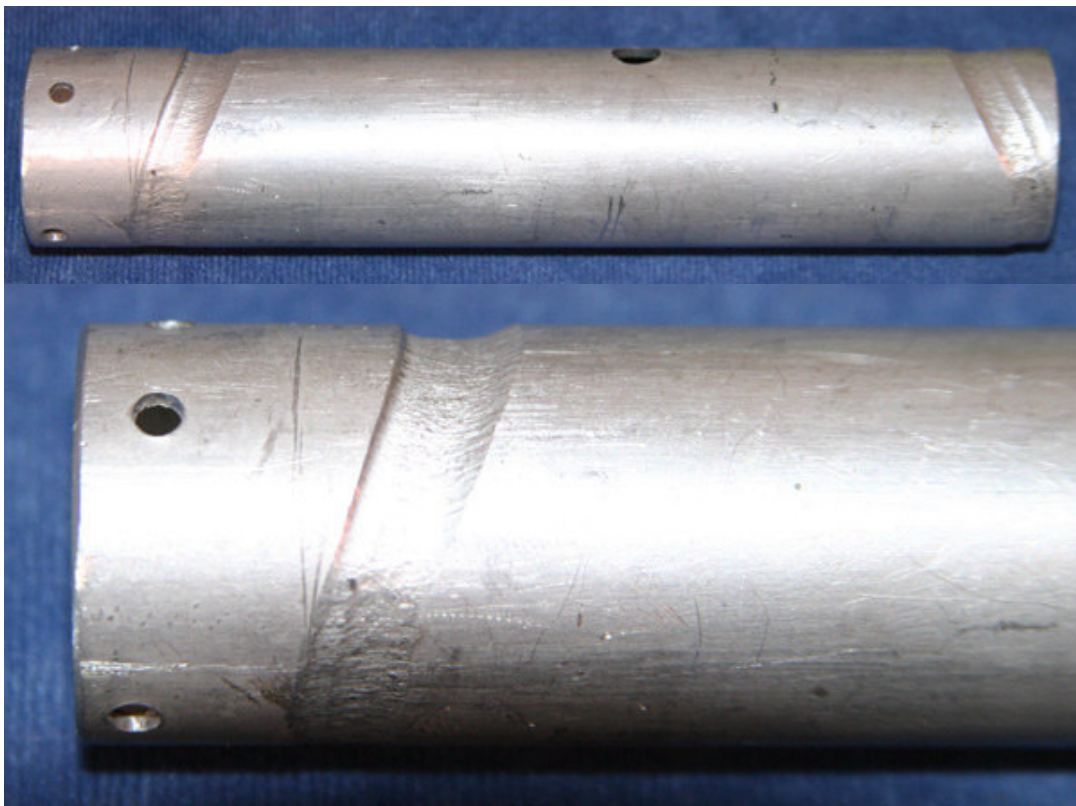

Figure 2: an example of extreme, totally unacceptable wear