

MICROLIGHT AIRWORTHINESS APPROVAL NOTE

MAAN NO: 2073

ISSUE 1

DATE: 30 March 2007

TITLE: Microlight Airworthiness Approval Note 2073,
Shadow Service Bulletin BMAA 2073.

Applicability: All Shadow variants

STAGE: Authorisation

1. INTRODUCTION

The CFM Shadow is a type approved microlight aeroplane described in Microlight TADS BM6, BM19, BM40, BM41 & BM55.

This MAAN authorises the issue of a recommended inspection service bulletin. This service bulletin is appended to this MAAN for information. The bulletin advises inspection of hanger tube brackets F153 for cracks or defects following the failure of such a bracket on an Argentinian registered example of the type.

2. BASIS FOR APPROVAL

Not applicable.

3. DESCRIPTION

The inspection requests owners to examine the 2-off F153 hanger tube brackets on their aircraft for cracks and defects on an annual basis and to report any findings to the BMAA.

4. TECHNICAL INVESTIGATION

This inspection is classified as 'recommended' on the basis that the aircraft on which the defect was found was an Argentinean registered aircraft fitted with parts that are believed to be made of a different material than fitted to the UK fleet. No problem with the UK Shadow fleet is anticipated, nor is there any history to suggest that there is an existing problem.

5. FLIGHT TESTING

Not required.

6. MANUALS, PLACARDS AND INFORMATION

The maintenance schedule in the operator's manual should be amended to incorporate the inspection contained within the service bulletin. The service bulletin should be appended to the operator's manual. Compliance with this service bulletin is to be recorded in the aircraft's airframe and engine logbooks. This may be recorded by the owner.

7. NOISE CERTIFICATION

Not affected.

8. RADIO

Any aircraft radio installation is not affected by this note.

9. INSPECTION

To the TADS appropriate to the type, in its latest version, plus the Service Bulletin attached as appended to this MAAN.

10. WEIGHT AND BALANCE

Not affected.

11. SIGNIFICANT FEATURES AND LIMITATIONS

Not affected.

12. CERTIFICATION

I authorise issue of Shadow Service Bulletin BMAA MAAN 2073, as appended to this MAAN.

Prepared by:

Authorised by:

J A F Viner
Chief Technical Officer
British Microlight Aircraft Association

J A F Viner
Chief Technical Officer
British Microlight Aircraft Association

Initial Distribution:

Mr A Love, CAA Aircraft Projects Dept (Gatwick)
Mr R Bedwell, CAA Regional Office (Gatwick)
CAA Applications and Certifications Section (Gatwick)
Shadow Flight Centre
Shadow type file
MAAN file 2073
Owners of BMAA Shadow types (SB only)

BMAA – AIRCRAFT SERVICE BULLETIN

<i>Title: Shadow variants: Inspection of hanger tube brackets</i>	
<i>Reference: SB BMAA MAAN 2073 issue 1</i>	<i>Applicability: All UK Shadow variants administered by the BMAA</i>
<i>Issue date: 30 March 2007</i>	
Recommended inspection.	
This SB should be actioned before the next Permit Revalidation inspection.	

1. Introduction

Why has this Service Bulletin been issued?

Following a cracking failure of a F153 Hanger Tube Bracket on an aircraft in Argentina, the following inspection has been introduced to monitor these brackets to see if a significant problem exists. There have been no reports in the UK of any such failure of these brackets.

What aircraft are affected?

All CFM Shadow variants administered by the BMAA. (Note that for PFA administered Shadow aircraft, PFA Airworthiness Information note MOD/206/004 applies.)

What parts are affected?

Part F153 Hanger Tube Bracket, which attaches the front hangar tube to the boom tube.

What documents are affected?

The aircraft's maintenance schedule.

2. Qualifications

Who may implement this Service Bulletin?

The owner/operator or their employee may implement this service bulletin.

Who may certify that this Service Bulletin has been properly carried out?

The inspection part of this service bulletin does not require an independent check; however, if the part F153 is removed or any part of the wing or control system dismantled, then a second, independent signature is required (this may be another pilot qualified to fly 3-axis microlights or a BMAA inspector).

Where must record be made of the Service Bulletin?

Entries must be made in the aircraft's airframe logbook.

3. What is required to implement this Service Bulletin?

Wheel chocks.

BMAA – AIRCRAFT SERVICE BULLETIN

Title: Shadow variants: Inspection of hanger tube brackets

Reference: SB BMAA MAAN 2073 issue 1

*Applicability: All UK Shadow variants
administered by the BMAA*

Issue date: 30 March 2007

Recommended inspection.

This SB should be actioned before the next Permit Revalidation inspection.

A bright electrical torch.
2 people.

4. How to implement this Service Bulletin

1. Firmly chock the main wheels to prevent them moving during the inspection.
2. From the rear cockpit, equipped with a good light source, inspect the F153 plates for cracks and any evidence of movement or fretting within the hanger tube and the bolts for tightness.
3. Whilst inspecting the plates, ask a helper to gently push the wing fore and aft and check visually, and by feel, for any signs of movement between the plate and the hanger tube.
4. Next try using a firm vertical force applied at the point where the wing strut attaches to the wing. **WARNING:** do not exert lifting pressures at the wing tip.
5. Repeat steps 3 & 4 on the other wing.
6. Any evidence of undue movement or fretting should be investigated. If unsure, the F153 may be removed from the aircraft for a detailed inspection. If everything appears normal, then return the aircraft to service.
7. Any adverse findings should be reported to the BMAA.

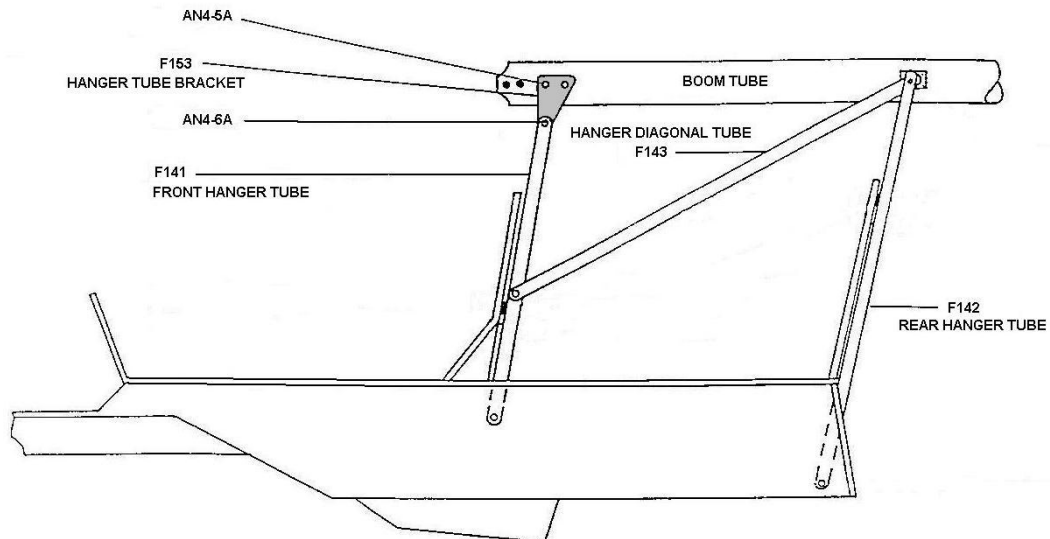

BMAA – AIRCRAFT SERVICE BULLETIN

<i>Title: Shadow variants: Inspection of hanger tube brackets</i>	
<i>Reference: SB BMAA MAAN 2073 issue 1</i>	<i>Applicability: All UK Shadow variants administered by the BMAA</i>
<i>Issue date: 30 March 2007</i>	
Recommended inspection.	
This SB should be actioned before the next Permit Revalidation inspection.	

5. Changes to operating data

Changes to Weight and Balance

None

Changes to the Operator's Manual

A copy of this service bulletin should be retained with the Operator's Manual.

Changes to the Maintenance Manual

The maintenance schedule should be amended to incorporate the inspection contained within this service bulletin.

Changes to Placards

None.

6. Authorisation

This Service Bulletin has been authorised by the BMAA Chief Technical Officer.

Authorised by

J A F Viner
Chief Technical Officer
British Microlight Aircraft Association

Initial Distribution:

- All registered owners of BMAA registered Shadow owners
- Shadow Flight Centre
- MAAN file 2073
- PFA engineering
- CAA: (1) Mr A Love (Aircraft projects, Gatwick)
(2) Mr R Bedwell (Regional office, Gatwick)

BMAA, Bullring, Deddington, Oxfordshire, OX15 0TT
01869 336006
cto@bmaa.org

